

# Flo-DrumSieve

Externally-fed Rotating Drum Screen

SGR

SAVI

## Value Engineered for Enhanced Performance & Reduced Cost



Flo-DrumSieve externally-fed drum screen

The Flo-DrumSieve externally-fed screen with stainless steel wedgewire media has a unique advantage - a very small footprint relative to the high flow rate and solids loading it can handle. Thus, industrial and municipal customers have found it to be one of the most flexible screens to install.

Wedgewire is the recognized standard for scum screening in municipal applications and is particularly effective in capturing hard to screen solids such as greasy material in industrial applications. The Flo-DrumSieve screen is also used as pre-treatment screening for certain small flow MBR installations.

As influent enters the headbox of the unit, a distribution baffle slows the liquid allowing it to pass up and over the exterior of the screen at a consistent flow. Solids are

collected on the outside of the screen and are removed by a brass cleaning blade.

Liquid passes through the screen and creates a self-cleaning action on the opposite side of the screen cylinder as it rotates. The interior of the screen cylinder is equipped with a spray bar, either high or low pressure depending on the application, that supplements the self-cleaning process.

An integral tank below the screen collects the filtrate and directs it through the discharge outlet.

## Features & Benefits

- 1 Deep headbox with distribution baffle** - Wastewater is distributed evenly across the exterior surface of the screen.
- 2 Self-cleaning screen** - Screened wastewater passes through the cylinder automatically cleaning the opposite side of the screen as it rotates.
- 3 A single brass cleaning blade removes solids from the screen surface** - No secondary cleaning mechanisms are required.

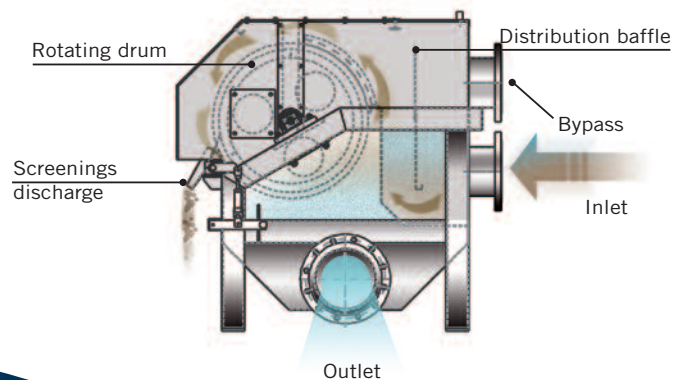

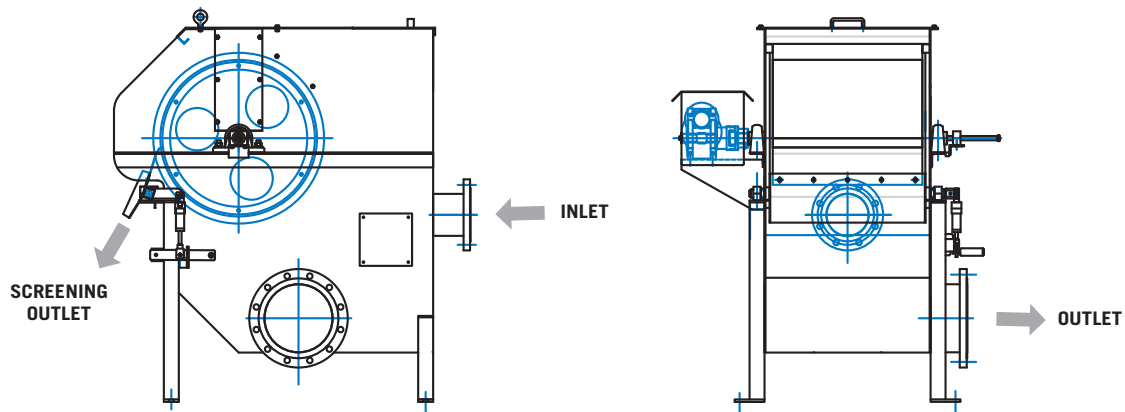

## Specifications

Wedge wire opening	mm	0.25 - 2.50
Flow rates	gpm	44 - 9200
Wash water pressure	bar	3 - 6
Nozzle opening (std)	mm	250
Power	kW	0.37
Electric motor		3P 460V 60Hz IP55

## Materials of Construction

Frame	SST	AISI 304
Wedge wire cylinder	SST	AISI 304
Discharge tank	SST	AISI 304
All components/fasteners	SST	AISI 304
Cleaning blade		Brass



**SAVECO**  
Member of WAMGROUP

1570 St. Paul Avenue  
Gurnee, IL 60031 U.S.A.  
P. 815.636.8306 • F: 847.672.7968

[ecsales@savecowaterna.com](mailto:ecsales@savecowaterna.com)  
[www.savecowaterna.com](http://www.savecowaterna.com)