

FSM® Center Flow Screen

Perforated Media Screen With Inside-Out Flow

FRS-CF



- Excellent MBR Pretreatment Screen
- Lowest Headloss
- Highest SCR Value Independently Verified



FSM® Center Flow Screen - FRS-CF

Perforated Media Screen With Inside-Out Flow

84% Capture Ratio (SCR) Thompson RPM Test Certified

Over 40 years of screening experience has led to a screen design that combines high capture with low operating costs. In October 2015, the results of Thompson RPM testing certified an average screenings capture ratio of 84% using 6 mm perforated media for the FSM Center Flow Screen. This high percentage is made possible by the inside-out flow design with no carry over to the downstream side of the screen.

The first FSM CenterFlow screens were designed to screen river intake water for power plant cooling water. This application requires reliable performance under changing conditions. As the demand for primary treatment and fine screening for wastewater grew, FSM modified the CenterFlow screen for this application. The goal was to produce a screen that could handle all the variables of wastewater and plant design in both municipal and industrial wastewater applications while maintaining low operating costs. To date, hundreds of installations worldwide prove the goal was achieved.

Principle of Operation

Filter panels are attached to the screen frame forming a continuous, U-shaped filter belt assembly. Wastewater is introduced into the filter belt assembly on the inside at the mid-point of the frame. Screening occurs as the wastewater flows from the inside to the outside of both sides of this U-shaped filter belt.

As the filter belt rotates around the frame, individual filter elements capture solids on the surface of the perforated media. Larger solids form a mat which, in turn, captures smaller solids as the filter belt moves toward discharge. The screen panels and screen frame are sealed at the sides to prevent the bypassing of solids. Since screening and discharge all take place on the inside of the filter belt assembly, there is no carry over to the upstream side of the Center Flow screen.

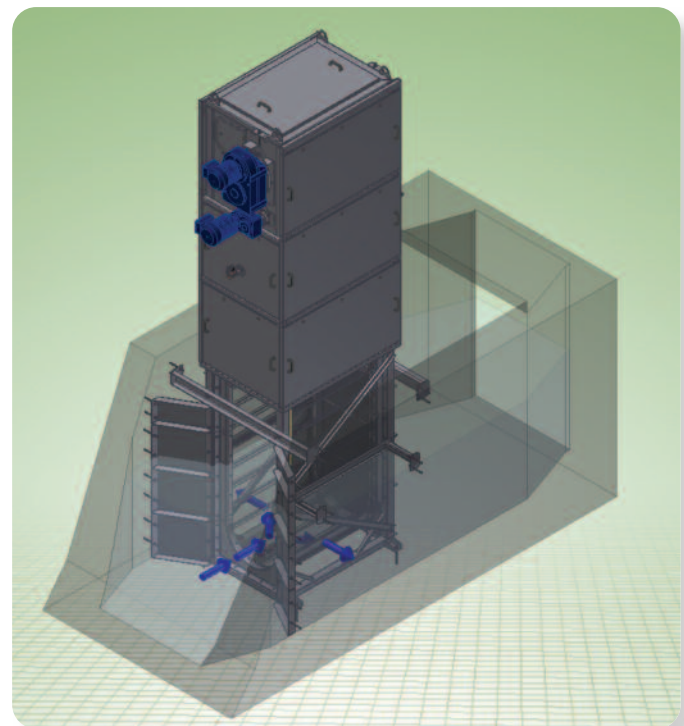

Solids are captured on the inside of the screen panels.

A spray bar located at the apex of the U-shaped filter belt assembly cleans the solids from the filter elements. An optional brush is available for heavy solids loading applications. Solids captured on the panel surface are deposited into a trough just below the apex of the filter belt. Screenings can be discharged into flumes, containers, conveyors or an FSM high performance washer compactor.

Filter elements can be individually inspected and replaced at the operating platform by rotating the filter belt to the desired location. Filter elements are available in stainless steel perforated media or UHMPE. Stainless steel woven mesh is also available.

Applications

- Membrane pre-treatment – fine screening protection.
- Municipal & Industrial wastewater.
- Raw water intake – river and sea water screening.
- Power station intake water screening.



Special side seals on the frame prevent by pass.

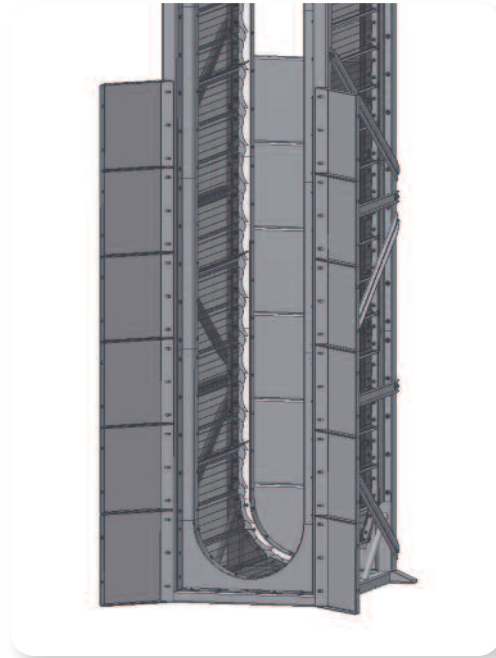

Sealing between machine frame and channel.



Solids are collected just below the discharge point at the apex of the filter belt.

Important Features

- Inside/Out screening.
- Designed to eliminate solids carry over.
- Heavy duty construction reduces maintenance costs.
- Excellent cost / performance ratio.
- Screen easily adapts to changing operating conditions.
- Suitable for outdoor sites / and cold weather operation.
- Fully enclosed for maximum odor control.
- Optional fish trays available for river, lake and sea water screening applications.



Completely Enclosed for Odor Control.



No carry over of screenings to downstream process.



Fayetteville, Arkansas

Specifications

Capture ratio	84% with 6 mm perf. (verified by independent testing)
Inclination	90 degrees
Perforations	2 to 12 mm
Mesh	0.5 to 6 mm
Channel widths	to 16 feet.
Discharge Heights	up to 50 feet in the standard design (larger heights upon request)

Materials of Construction

Frame	304 SS construction (316 SS optional)
Chains, Sprockets, Supports	304 SS (Optional 316 SS)
Rollers	Stainless steel and PA 6
Side Seal	HDPE



SAVÉCO
Member of WAMGROUP®

1570 St. Paul Avenue
Gurnee, IL 60031 U.S.A.
P. 815.636.8306 • F: 847.672.7968

ecsales@savecowaterna.com
www.savecowaterna.com